

UNLESS OTHERWISE SPECIFIED , TOLERANCES XX.X0 ± 0.25
 0.XX ± 0.05

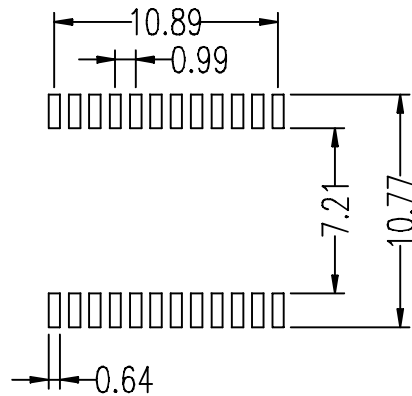

PCB SUGGEST PAD LAYOUT

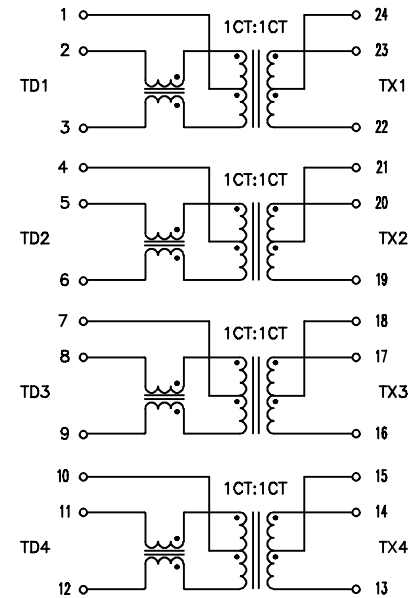

ELECTRICAL CHARACTERISTICS :

- INSULATION HI-POT(PRI./SEC.) : 1500Vrms
- TURN RATIO (±5%) : TX = 1CT : 1CT
RX = 1CT : 1CT
- OCL : 350uH MIN. 100KHz/0.1V AT 8mA DC BIAS
- INSERTION LOSS : 0.1-100MHz = -1.0dB MAX.
- RETURN LOSS (dB MIN.) : 1-30MHz 40MHz 50MHz 60-80MHz
-18 -14.4 -13.1 -12
- CROSS TALK (dB MIN.) : 30MHz 60MHz 80MHz
-40 -35 -35
- COMMON MODE REJECTION (dB MIN.) : 30MHz 60MHz 100MHz
-43 -37 -33
- RoHS COMPLIANT

								TITLE 100/1000 BASE-TX TRANSFORMER	
								DWG. NO. ATPL-396R	
RELEASE						UNITS:		SAFETY	
NO: DESCRIPTION DATE BY CHK APPD						DATE		P/N:	
REVISIONS								SHEET 1 of 1	
								DRAW	